

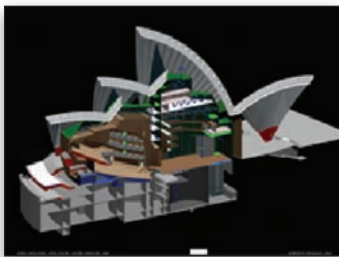

Bentley® Architecture V8i

A Comprehensive Building Information Modeling (BIM) Solution for Architectural Design, Building Performance Analysis and Documentation

Bentley Architecture V8i is for team members responsible for project performance and organization. It supports all phases of the architectural workflow, from conceptual design to construction documentation, and integrates design, visualization, drawing production, and reporting of quantities and costs.



*Sydney Opera House renovation
(Courtesy Johnson Pilton Walker/Arup)*



*Integrated design and visualization
(Courtesy PLH Architects)*

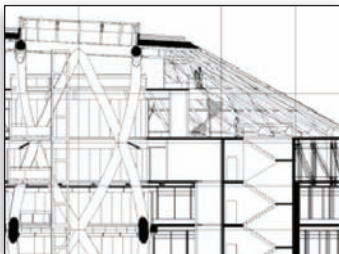

*Detailed section
(Courtesy PLH Architects)*

Interactive Dynamic Views in V8i

Utilizing dynamic views, Bentley Architecture V8i automatically coordinates architectural design and construction documentation through all project phases, and manages inherent component attributes and properties significant for design, documentation, analysis, construction, and operations. 'Illustration mode' and 'Illustration with Shadows' provide impressive visual feedback to the client and co-workers. Many new rendering modes are available and user customizable. Bentley Architecture V8i shares a common graphics platform with over 200 Bentley applications allowing them to work together.

With interactive dynamic views, users can work in 2D or 3D and see both update dynamically making it possible to save time coordinating plan sets, improve the quality of deliverables, simplify the 3D modeling experience, and improve interactive visualization.

Working in 3D is easier because users can, slice and filter 3D models, remove clutter from the working view, see only what's needed in any view at any time, drag and drop plans, elevations and sections to create documentation.

Also, interactive dynamic views automate 2D updates for full drawing package coordination. This means that teams can, quickly improve the quality of integrated documentation packages, reduce the time spent creating 3D models, spend less time preparing and coordinating 2D documentations, and update linked annotation dynamically.

Parametric Design

Building components are parametric, allowing dimension-driven creation and modification. Rules can be defined to capture design intent, dimensional constraints, assembly relationships, and more.

Advanced and Complex Geometry

A full range of advanced solids modeling tools are provided, which allow the creation of virtually any form. Unlike applications that use facets to emulate curved surfaces, Bentley Architecture V8i creates truly curved and double-curved surfaces and solids for accurate construction information and smooth rendering.

Choice of 2D, 3D, or Both

The building information model can be created and manipulated in a traditional 2D plan or an advanced 3D model environment – using the same tools and interface for either. Floor plans, sections, and elevations comply with user-definable drawing standards, such as symbology, patterning, annotation, and dimensioning, ensuring coordination and consistency across all documentation.

Comprehensive Schedules and Reporting

User-definable properties associated with building components are used to query the Building Information Model, to make selective or global changes to the geometry and nongraphical information, and to generate accurate quantity and cost reports, schedules, and specifications.

A Managed Environment

Bentley Architecture V8i can be integrated on a single platform with ProjectWise, a collaboration server that manages access to project information across a LAN, WAN, VPN, or through the Internet, and publishes and synchronizes shared information, manages change, protects intellectual property rights, and more.

Integrated Design Visualization

Powerful rendering, animation, lighting, and camera controls provide immediate visual feedback and streamline the creation of convincing presentations without the need to export data to an external visualization application.

System Requirements

Software:

MicroStation V8i® v8.11 or higher

Processor:

Intel-compatible Pentium PCs running Microsoft Windows 2000, Microsoft Windows NT or Microsoft Windows XP, Microsoft Windows 7.

Memory:

Minimum 1 GB

Hard disk:

200 MB minimum free

Input device:

Mouse or digitizing tablet (tablet on Windows requires WINTAB driver or Bentley's Windows Digitizer Tablet Interface)

Output Device:

Majority of industry-standard devices supported; works with Windows-supported printers

Graphics card supported by DirectX 9.0c.

Find out about Bentley at: www.bentley.com

Contact Bentley

1-800-BENTLEY (1-800-236-8539)
Outside the US +1 610-458-5000

Global Office Listings

www.bentley.com/contact

Bentley Architecture V8i At-A-Glance

Building Information Modeling (BIM)

- Coordinated architectural design and construction documentation
- Relationships and associativity between architectural elements for rapid design changes
- Dynamic views allow user to work in 2D or 3D with automatic update of drawings when the 3D model is changed
- Work in plan, elevation, isometric, or perspective view
- Inherent component attributes and properties significant for design, documentation, analysis, construction, and operations

Parametric Design and Feature Modeling

- Dimension-driven creation and modification of building components
- Embedded parameters, rules, and constraints to capture design intent
- Solid modeling for easy creation of virtually any form
- Double-curved surfaces and solids for accurate construction information and smooth rendering

Coordinated Construction Documentation

- Coordinated creation of floor plans, sections, and elevations
- Material-dependent hatching/patterning, annotation, and dimensioning
- Room and component schedules, quantity and cost calculation, specifications

- Compatibility with office automation tools for further processing and formatting
- Automatic resymbolization of 3D objects to 2D symbols

Design Visualization and 3D Output

- High-end integrated rendering and animation tools including the Luxology rendering engine which provides near real-time rendering
- Export to STL to support rapid model making and proto-typing with 3D printers and stereo lithography machines
- Output to 3D PDF
- Support of 3D Web formats, such as VRML, QuickVision, panoramas

Support of 3D within Adobe PDF

- Create Adobe PDF documents with embedded 3D models and renderings directly from Bentley Architecture V8i
- Include DGN and DWG drawings, project documents, renderings, and interactive and animated 3D models
- Navigate the model using hyperlinks and bookmarks
- Support of international and custom standards
- Create, manage, verify, and enforce company and project standards

Support for U.S. and other National CAD Standards

- Viewing of ADT multiview blocks

- Support of DGN, DWG, DXF, PDF, STEP, IGES, IFC, and other major industry standards

Interoperability with Building Engineering, Analysis and Facilities Management

- Fully integrated with Structural Modeler V8i, Bentley Building Mechanical Systems V8i, Bentley Building Electrical Systems V8i, Bentley Facilities V8i, and more
- A shared multidisciplinary model for team collaboration and coordination
- Review and manage interferences across multiple files and disciplines in conjunction with ProjectWise Clash Resolution Visa
- Simulated construction schedules in conjunction with ProjectWise Navigator V8i and project management applications, such as Microsoft Project or Primavera P3
- Facilitated by Bentley's newly introduced i-model (a container for open infrastructure information exchange), Bentley Architecture V8i maximizes the interoperability of information between different specialized applications, CAD and BIM platforms, and design reviews of a project's architectural information.

Integration with Managed Environment

- Fully supported in ProjectWise, Bentley's comprehensive collaboration server

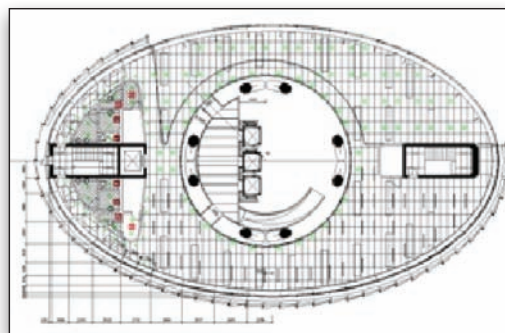

Floor plan extracted from BIM model
(Courtesy PLH Architects)

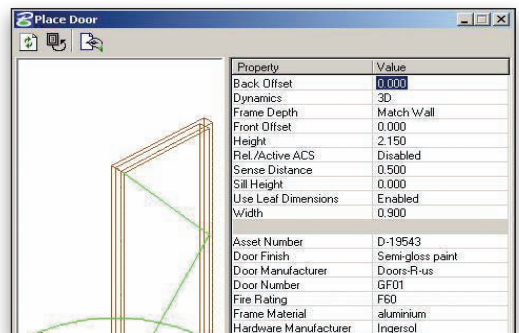

Parametric objects with user-definable properties